

# Wi-Fi Video Doorbell Camera and Wireless Chime Installation Guide



Model: RVDBA701000A



For additional languages, use a QR scanner to scan the QR code

## 1. What's in the Box

- 1x Wi-Fi Doorbell With Camera
- 1x Wireless Doorchime
- 2x Window security sticker
- 1x Adaptor 12V DC /1A
- 1x Micro SD Card 32GB (Pre-installed In The Camera)
- 1x Extension Cable For Adaptor
- 1x 15°Bracket
- 1x Ethernet Cable (Optional Use)
- 1x Position card
- 1x Screw Pack With Screw Driver
- 1x Quick Start Guide

## 2. Product Overview

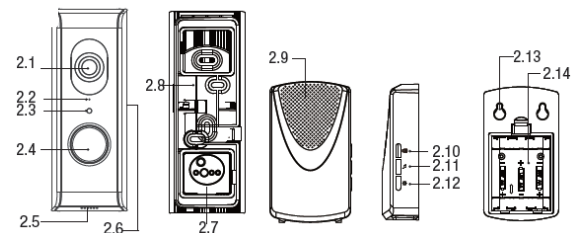

- 2.1 Lens
- 2.2 Microphone
- 2.3 Day/night sensor (automatically)
- 2.4 Push button
- 2.5 Loudspeaker
- 2.6 Micro SD card slot (inside housing)
- 2.7 Rubber cover for wiring
- 2.8 Release pin for bracket and doorbell
- 2.9 Chime Loudspeaker
- 2.10 Volume Settings
- 2.11 Melody Settings
- 2.12 No function when bundle using with Wi-Fi Doorbell
- 2.13 Wall mount holes
- 2.14 Battery compartment (3x AA batteries, excluded)

## 3. Wi-Fi Doorbell Connections

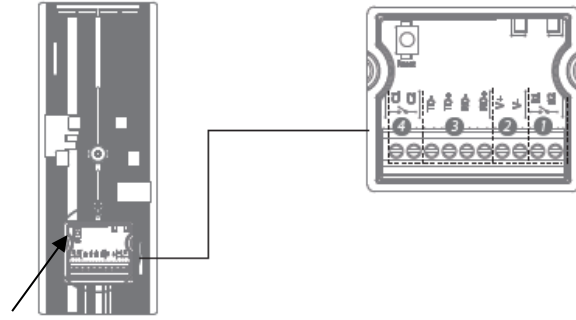

Reset button

1. Reset button (Hold for 10 seconds)
2. Connection for electrical lock (B1, B2 / 0V)
3. RJ45 internet cable connection (TD-, TD+, RD-, RD+)
  - TD- = Internet cable, Orange color wire
  - TD+ = Internet cable, Orange / White color wire
  - RD- = Internet cable, Green color wire
  - RD+ = Internet cable, Green / White color wire

**Note:** Wired internet works only when you first connect the internet cable to the Wi-Fi doorbell and router. After that, insert the adapter in the socket.

4. Adapter connection (V+, V- / 12V 1A)
  - V+ = Red Wire
  - V- = Black wire

**Note:** Pay attention to connect correctly.

5. Wired Chime indoor connection (C1, C2 / 0V): the mechanical Chime must be powered by an 8V AC transformer. The separate power supply is AC, so it makes no difference which wire goes to C1 and C2 (see APPENDIX).

## 4. Preparation Before Installation using your Smart Device

To install the Wi-Fi doorbell, you need to prepare the following information.

- **Your Wi-Fi Username and Password:** the Wi-Fi doorbell must be registered on your own Wi-Fi network during this installation.
- **During the installation keep your phone close to the Wi-Fi Doorbell (max. 1 meter)**
- **Connection of the Smart Phone to the Doorbell is established through Bluetooth Communication.**  
*Note: This procedure can take up to 3 minutes.*
- **First perform the setup as explained in these instructions and then install the Wi-Fi doorbell on your front door.**

## 5. Installation

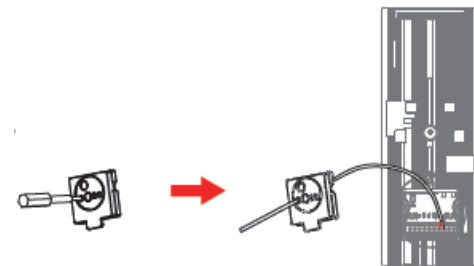

1. Remove the rubber cover (2.7) on the rear of the Wi-Fi doorbell.
2. Connect the adaptor with the extension cord.
3. Use a screwdriver to punch a hole into the rubber cover.
4. Insert the extensions cord through the rubber cord.
5. Connect the extension cord to the Wi-Fi doorbell (V+ red wire, V- black wire).
6. Insert the adaptor into the power socket.
7. Close the rubber cover (2.7).

**Note:** Do not connect an internet cable during the installation.

## 6. Connecting the Wi-Fi Doorbell to your Wi-Fi Network

1. Open the RISCO HandyApp on your smart phone.
2. Enter the Configurator and then click Video Doorbell Settings.
3. Identify the new Video Doorbell and then select one of the following two options:
  - Smart Setup** – proceed to step 4 below.
  - Wired Connection** –
    - a. Connect the Video Doorbell to the Wi-Fi network as described below.
    - b. Unplug the Video Doorbell from the electrical outlet.
    - c. Connect the Video Doorbell according to the Wiring Diagram (see APPENDIX).
    - d. Plug the Video Doorbell back into the electrical outlet.
4. Power up the Video Doorbell and wait for the announcement that the Video Doorbell is ready.

**Note:** Make sure the LED is flashing on the Video Doorbell.

A list of Wi-Fi networks that the doorbell “sees” is displayed.

5. Select the Wi-Fi network that you want the Video Doorbell to connect to.
6. Enter the password for the selected Wi-Fi network. The doorbell has now been successfully connected to the Wi-Fi network.
7. Click Additional Settings.



8. Enter a name for the Video Doorbell and then click Done.

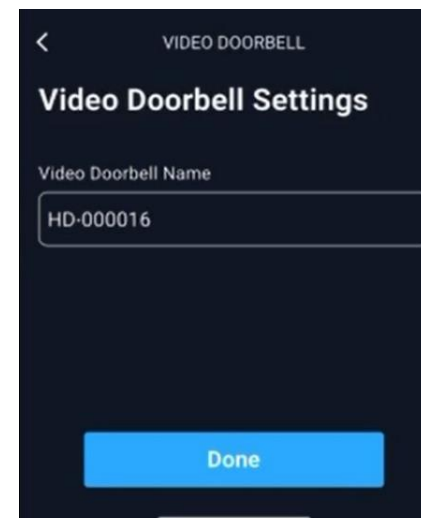

9. Assign the Video Doorbell to a Site on the RISCO Cloud by following the straightforward instructions on the screen that opens. Once the video doorbell is registered in the site and ready for use, continue below.

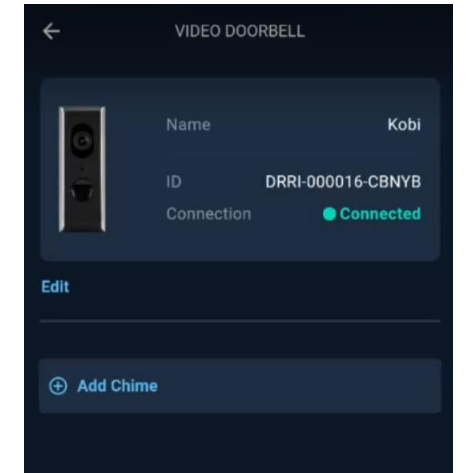

10. Click Perform Video Test.

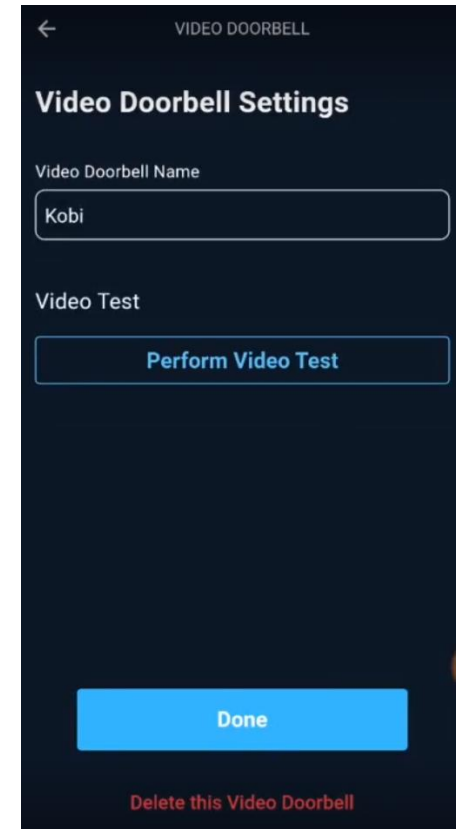

The Video Doorbell now presents a livestream of what the Video Doorbell “sees”.

## Adding Chime

**Note:** The Chime that arrives in the Video Doorbell kit is already registered in the Video Doorbell. Perform this section to register an additional Chime.

1. Click Add Chime.
2. With the batteries not installed in the Chime, click Start Chime Pairing.
3. Enter the batteries.

**Note:** You will have 30 seconds to enter the batteries for successful pairing.

## 7. Video Doorbell Buttons and Settings via iRISCO App

The iRISCO app allows the end user to operate and setup the video doorbell.

1. Open the iRISCO App on the smart phone.
2. Press  (the menu button) at the top left corner of the screen.
3. Select VIDEO DOORBELLS from the menu.
4. Select a Video Doorbell.

The Video Doorbell view is displayed. You can now operate and setup the Video Doorbell and to view the Event Log.

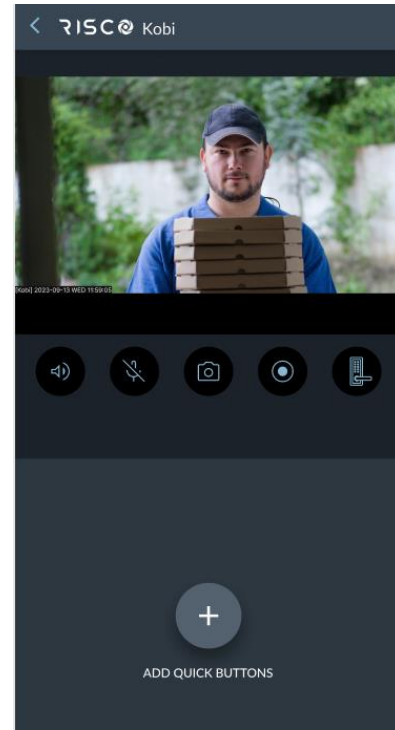

### Video Doorbell Buttons

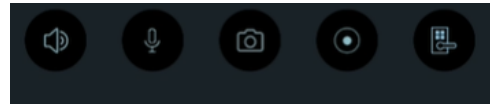

Speaker    Mic    Take photo    Record (30 sec constant period)    Open Door Lock

### Video Doorbell Settings

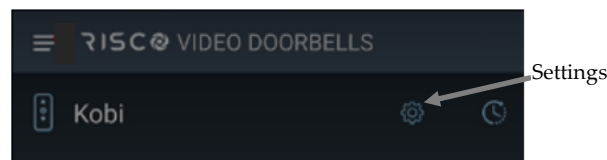

Click Settings in the Video Doorbells list screen.

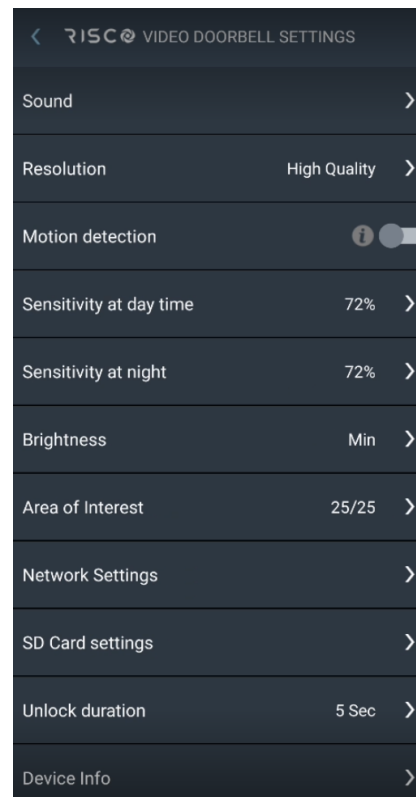

Configure the above settings as required.

#### Motion Detection:

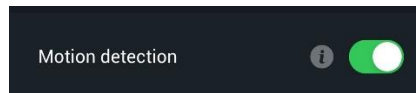

When Motion Detection is set to ON, the camera will send a push notification when motion is detected.

#### Sensitivity:

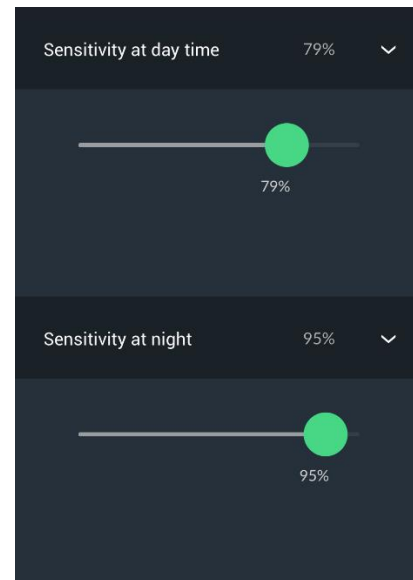

Drag the slider left or right to adjust detection sensitivity for both day and night:

0% = lowest detection sensitivity  
100% = highest detection sensitivity

#### Area of Interest:

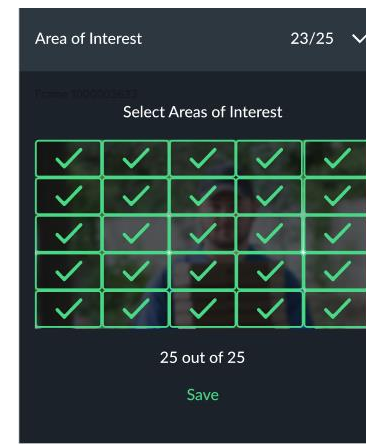

Select the boxes that cover the area where you want motion detection to be effective.

#### Event Log

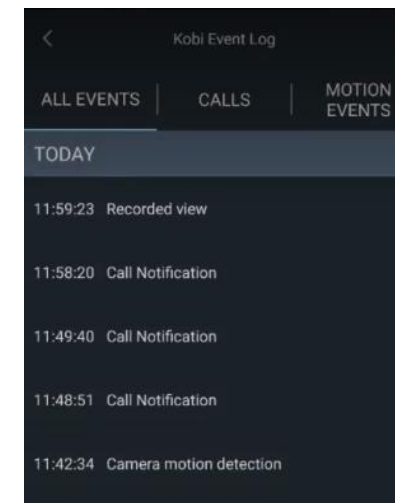
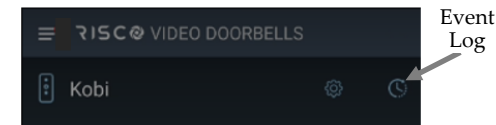

## Specifications

### Video Doorbell

	Parameter	Description
Image Sensor	CMOS Size	2 Megapixel, 1/2.9 inch
	Resolution	1080P(1920 H*1080V)
Relay	Current Consumption	2A/30Vdc or 0.3A/125VAC, NO (cannot be changed)
Lens	Lens Focal Length:	2.7mm
	IR CUT	Supported
Video Parameter	View Angle	H: 115±5° V: 57±5° FOV: 140±5°
	Compression	H.264
	Live view Resolution	1080P / 720P / VGA
	Frame Rate	15FPS
	Day & Night Model	Yes (Color doe Day time/ B&W for Night Time)
	Smart IR	Support
Audio Parameter	Object Detection	Supported up to 3M
	2-Way Audio	Supported
	Volume Adjustable	Supported
Network Parameter	Ethernet Network	Supported
	Wi-Fi Network	Supported

	Parameter	Description
Wi-Fi Parameter	Bluetooth	Supported for Wi-Fi Setup Only
	Frequency	2400-2483.5MHz
	Power Mode	DC 9V-48V
Power Consumption	Power Supply	IR Off: Average 160-200mA Max 400mA IR On: Average 200-280mA Max 500mA
		IR LED
LED Lighting Parameters	EDS	Environmental Digital Sensor
	LED Angle	120°
	LED Wavelength	850nm
	Visible Range	Up to 3 meters
Recording Parameter	Storage Media	TF Card
	Max Storage Capacity	128GB (32GB provided with the product)
	Recording File Format	MP4
	Recording Resolution	1080P
	Pre-Recording	3-sec
	Default Recording time	Default 30sec, Dynamic Recording time up to 60sec
I/O Interface	Reference Recording time (32GB)	26 hour, 2600 events typical
	Power IN	DC Power input
	SD/TF CARD:	TF card up to 128GB
	Reset/Pairing	Supported
	LED	x1 (Status Indication)
	Network Port	Combined in 10PIN holder
Environment	Operating temperature	-10-50°C
	Storage temperature	-20-60°C
	Working humidity	10%-95%RH
	Storage humidity	10%-95%RH
	IP Value	IP 55
	Dimintions (HxWxD)	113x49x24 mm

### Chime

Parameter	Description
Frequency	868MHz for EU market
Distance (VDB to Chime)	Up to 150m (Line of Sight)
Sound	3 levels Plus off
Melody	4 Melodies
Buttons	Music Selection Button Volume Button Pair Button
Battery Type	AA Battery x 3 (1 yr.)
Dimension (HxWxD)	105*60*28mm
Weight	146g ( battery included )



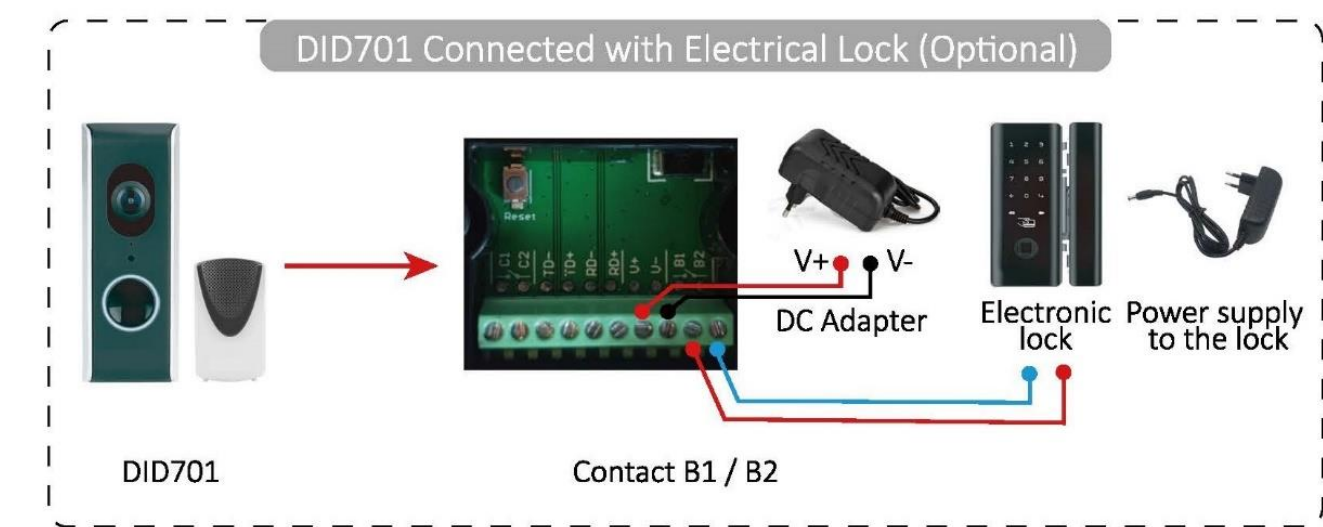
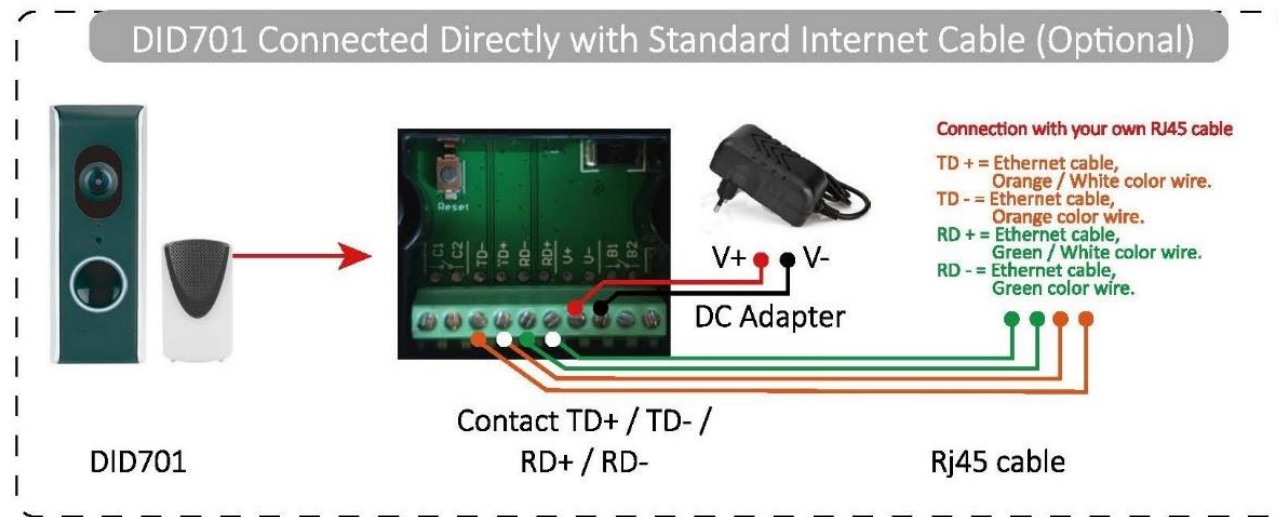
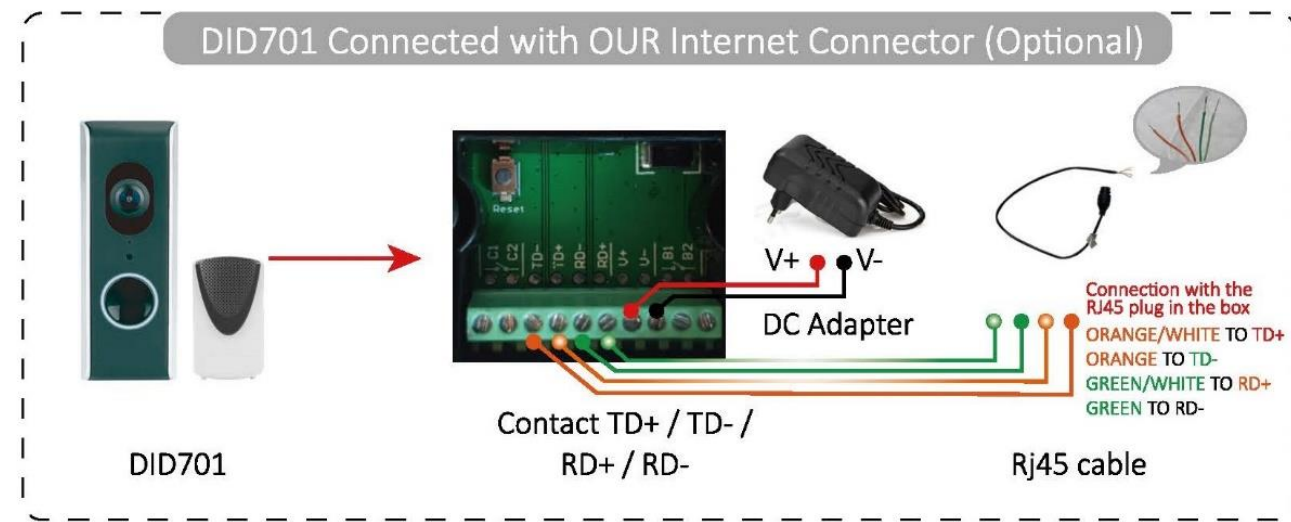
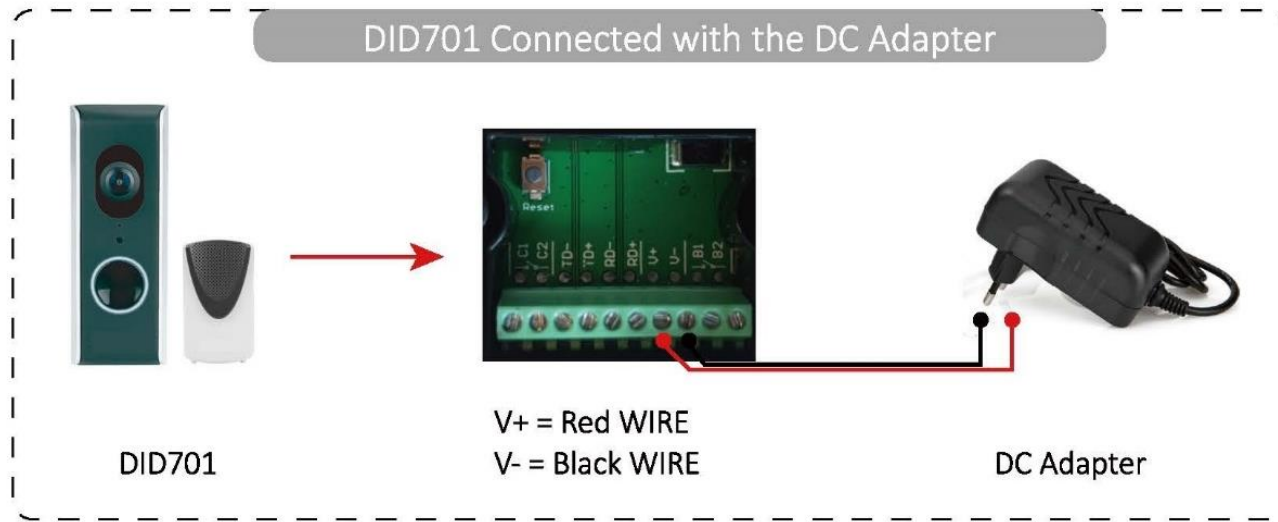

**RED Compliance Statement:**

Hereby, RISCO Group declares that this equipment complies with the essential requirements and other relevant provisions of Directive 2014/53/EU. For the CE Declaration of Conformity please refer to our website: [www.riscogroup.com](http://www.riscogroup.com).

**Standard Limited Product Warranty (“Limited Warranty”)**

RISCO Ltd. (“RISCO”) guarantee RISCO’s hardware products (“Products”) to be free from defects in materials and workmanship when used and stored under normal conditions and in accordance with the instructions for use supplied by RISCO, for a period of (i) 24 months from the date of delivery of the Product (the “Warranty Period”). This Limited Warranty covers the Product only within the country where the Product was originally purchased and only covers Products purchased as new.

**Contact with customers only.** This Limited Warranty is solely for the benefit of customers who purchased the Products directly from RISCO or from an authorized distributor of RISCO. RISCO does not warrant the Product to consumers and nothing in this Warranty obligates RISCO to accept Product returns directly from end users who purchased the Products for their own use from RISCO’s customer or from any installer of RISCO, or otherwise provide warranty or other services to any such end user directly. RISCO’s authorized distributor or installer shall handle all interactions with its end users in connection with this Limited Warranty. RISCO’s authorized distributor or installer shall make no warranties, representations, guarantees or statements to its end users or other third parties that suggest that RISCO has any warranty or service obligation to, or any contractual privity with, any recipient of a Product.

**Remedies.** In the event that a material defect in a Product is discovered and reported to RISCO during the Warranty Period, RISCO shall accept return of the defective Product in accordance with the below RMA procedure and, at its option, either (i) repair or have repaired the defective Product, or (ii) provide a replacement product to the customer.

**Return Material Authorization.** In the event that you need to return your Product for repair or replacement, RISCO will provide you with a Return Merchandise Authorization Number (RMA#) as well as return instructions. Do not return your Product without prior approval from RISCO. Any Product returned without a valid, unique RMA# will be refused and returned to the sender at the sender’s expense. The returned Product must be accompanied with a detailed description of the defect discovered (“Defect Description”) and must otherwise follow RISCO’s then-current RMA procedure published in RISCO’s website at [www.riscogroup.com](http://www.riscogroup.com) in connection with any such return. If RISCO determines in its reasonable discretion that any Product returned by customer conforms to the applicable warranty (“Non-Defective Product”), RISCO will notify the customer of such determination and will return the applicable Product to customer at customer’s expense. In addition, RISCO may propose and assess customer a charge for testing and examination of Non-Defective Product.

**Entire Liability.** The repair or replacement of Products in accordance with this Limited Warranty shall be RISCO’s entire liability and customer’s sole and exclusive remedy in case a material defect in a Product is discovered and reported as required herein. RISCO’s obligation and this Limited Warranty are contingent upon the full payment by customer for such Product and upon a proven weekly testing and examination of the Product functionality.

**Limitations.** This Limited Warranty is the only warranty made by RISCO with respect to the Products. The warranty is not transferable to any third party. To the maximum extent permitted by applicable law, this Limited Warranty shall not apply and will be void if: (i) the conditions set forth above are not met (including, but not limited to, full payment by customer for the Product and a proven weekly testing and examination of the Product functionality); (ii) if the Products or any part or component thereof: (a) have been subjected to improper operation or installation; (b) have been subject to neglect, abuse, willful damage, abnormal working conditions, failure to follow RISCO’s instructions (whether oral or in writing); (c) have been misused, altered, modified or repaired without RISCO’s written approval or combined with, or installed on products, or equipment of the customer or of any third party; (d) have been damaged by any factor beyond RISCO’s reasonable control such as, but not limited to, power failure, electric power surges, or unsuitable third party components and the interaction of software therewith or (e) any failure or delay in the performance of the Product attributable to any means of communication provided by any third party service provider, including, but not limited to, GSM interruptions, lack of or internet outage and/or telephony failure. BATTERIES ARE EXPLICITLY EXCLUDED FROM THE WARRANTY AND RISCO SHALL NOT BE HELD RESPONSIBLE OR LIABLE IN RELATION THERETO, AND THE ONLY WARRANTY APPLICABLE THERETO, IF ANY, IS THE BATTERY MANUFACTURER’S WARRANTY. RISCO does not install or integrate the Product in the end user’s security system and is therefore not responsible for and cannot guarantee the performance of the end user’s security system which uses the Product or which the Product is a component of.

This Limited Warranty applies only to Products manufactured by or for RISCO. Further, this Limited Warranty does not apply to any software (including operating system) added to or provided with the Products or any third-party software, even if packaged or sold with the RISCO Product. Manufacturers, suppliers, or third parties other than RISCO may provide their own warranties, but RISCO, to the extent permitted by law and except as otherwise specifically set forth herein, provides its Products “AS IS”. Software and applications distributed or made available by RISCO in conjunction with the Product (with or without the RISCO brand), including, but not limited to system software, as well as P2P services or any other service made available by RISCO in relation to the Product, are not covered under this Limited Warranty. Refer to the Terms of Service at: [www.riscogroup.com/warranty](http://www.riscogroup.com/warranty) for details of your rights and obligations with respect to the use of such applications, software or any service. RISCO does not represent that the Product may not be compromised or circumvented; that the Product will prevent any personal injury or property loss by burglary, robbery, fire or otherwise, or that the Product will in all cases provide adequate warning or protection. A properly installed and maintained alarm may only reduce the risk of a burglary, robbery or fire without warning, but it is not insurance or a guarantee that such will not occur or will not cause or lead to personal injury or property loss. CONSEQUENTLY, RISCO SHALL HAVE NO LIABILITY FOR ANY PERSONAL INJURY, PROPERTY DAMAGE OR OTHER LOSS BASED ON ANY CLAIM AT ALL INCLUDING A CLAIM THAT THE PRODUCT FAILED TO GIVE WARNING.

EXCEPT FOR THE WARRANTIES SET FORTH HEREIN, RISCO AND ITS LICENSORS HEREBY DISCLAIM ALL EXPRESS, IMPLIED OR STATUTORY, REPRESENTATIONS, WARRANTIES, GUARANTEES, AND CONDITIONS WITH REGARD TO THE PRODUCTS, INCLUDING BUT NOT LIMITED TO ANY REPRESENTATIONS, WARRANTIES, GUARANTEES, AND CONDITIONS OF MERCHANTABILITY, FITNESS FOR A PARTICULAR PURPOSE, TITLE AND WARRANTIES AGAINST HIDDEN OR LATENT DEFECTS, TO THE EXTENT PERMITTED BY LAW. WITHOUT LIMITING THE GENERALITY OF THE FOREGOING, RISCO AND ITS LICENSORS DO NOT REPRESENT OR WARRANT THAT: (I) THE OPERATION OR USE OF THE PRODUCT WILL BE TIMELY, SECURE, UNINTERRUPTED OR ERROR-FREE; (ii) THAT ANY FILES, CONTENT OR INFORMATION OF ANY KIND THAT MAY BE ACCESSED THROUGH THE PRODUCT SHALL REMAIN SECURED OR NON DAMAGED. CUSTOMER ACKNOWLEDGES THAT NEITHER RISCO NOR ITS LICENSORS CONTROL THE TRANSFER OF DATA OVER COMMUNICATIONS FACILITIES, INCLUDING THE INTERNET, GSM OR OTHER MEANS OF COMMUNICATIONS AND THAT RISCO’S PRODUCTS, MAY BE SUBJECT TO LIMITATIONS, DELAYS, AND OTHER PROBLEMS INHERENT IN THE USE OF SUCH MEANS OF COMMUNICATIONS. RISCO IS NOT RESPONSIBLE FOR ANY DELAYS, DELIVERY FAILURES, OR OTHER DAMAGE RESULTING FROM SUCH PROBLEMS. RISCO WARRANTS THAT ITS PRODUCTS DO NOT, TO THE BEST OF ITS KNOWLEDGE, INFRINGE UPON ANY PATENT, COPYRIGHT, TRADEMARK, TRADE SECRET OR OTHER INTELLECTUAL PROPERTY RIGHT IN ANY EVENT RISCO SHALL NOT BE LIABLE FOR ANY AMOUNTS REPRESENTING LOST REVENUES OR PROFITS, PUNITIVE DAMAGES, OR FOR ANY OTHER INDIRECT, SPECIAL, INCIDENTAL, OR CONSEQUENTIAL DAMAGES, EVEN IF THEY WERE FORESEEABLE OR RISCO HAS BEEN INFORMED OF THEIR POTENTIAL.

**Contacting RISCO**

RISCO Group is committed to customer service and Product support. You can contact us through our website ([www.riscogroup.com](http://www.riscogroup.com)) or at the following telephone and fax numbers:

<b>United Kingdom</b>	<b>France</b>	<b>Israel</b>
Tel: +44-(0)-161-655-5500	Tel: +33-164-73-28-50	Tel: +972-3-963-7777
<a href="mailto:support-uk@riscogroup.com">support-uk@riscogroup.com</a>	<a href="mailto:support-fr@riscogroup.com">support-fr@riscogroup.com</a>	<a href="mailto:support@riscogroup.com">support@riscogroup.com</a>
<b>Italy</b>	<b>Belgium (Benelux)</b>	
Tel: +39-02-66590054	Tel: +32-2522-7622	
<a href="mailto:support-it@riscogroup.com">support-it@riscogroup.com</a>	<a href="mailto:support-be@riscogroup.com">support-be@riscogroup.com</a>	
<b>Spain</b>	<b>United Kingdom</b>	
Tel: +34-91-490-2133	Tel: +44-(0)-161-655-5500	
<a href="mailto:support-es@riscogroup.com">support-es@riscogroup.com</a>	<a href="mailto:support-uk@riscogroup.com">support-uk@riscogroup.com</a>	

